

Valve/Cavity Compatibility

For additional information see Technical Tips on pages BC2-BC3.

		VALVE			
		Parker	Waterman	FPS	CEC
CAVITY	Parker	X	X	X	X
	Waterman	X	X	X	X
	FPS	X	X	X	X
	CEC	X	X	X	X

Performance Curve
Pressure Drop vs. Flow

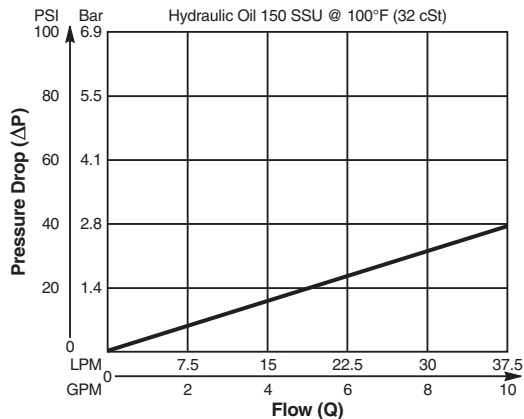

Dimensions Millimeters (Inches)

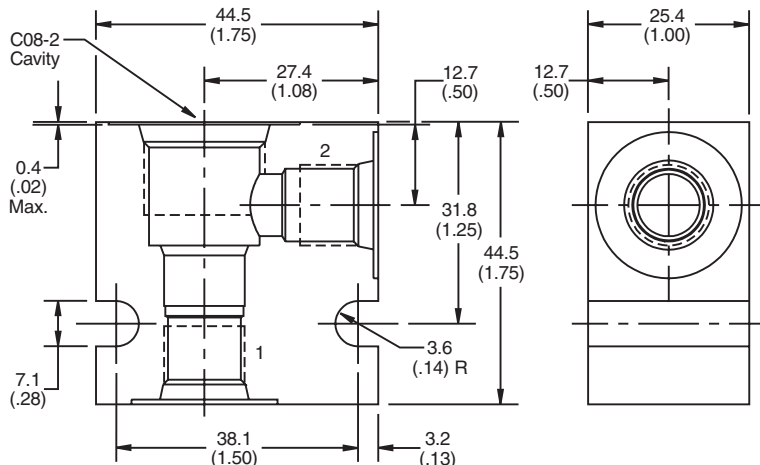
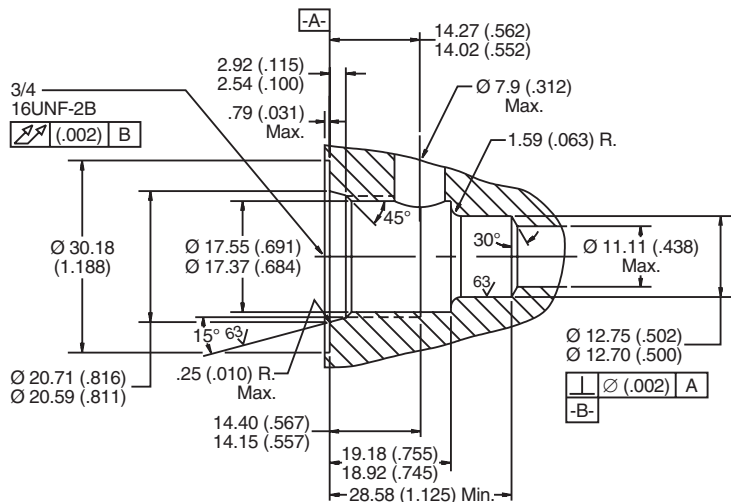

Ordering Information

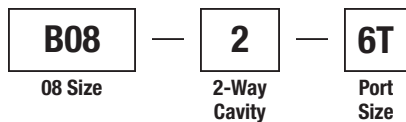

Code	Port Size
6T	SAE - 6/Steel (5000PSI)

Weight: .11 kg (.25 lbs.)

- CV
Check Valves
- SH
Shuttle Valves
- LM
Load/Motor Controls
- FC
Flow Controls
- PC
Pressure Controls
- LE
Logic Elements
- DC
Directional Controls
- SV
Solenoid Valves
- PV
Proportional Valves
- CE
Coils & Electronics
- BC
Bodies & Cavities
- TD
Technical Data